

代码/命名规则

Diode Device命名规则

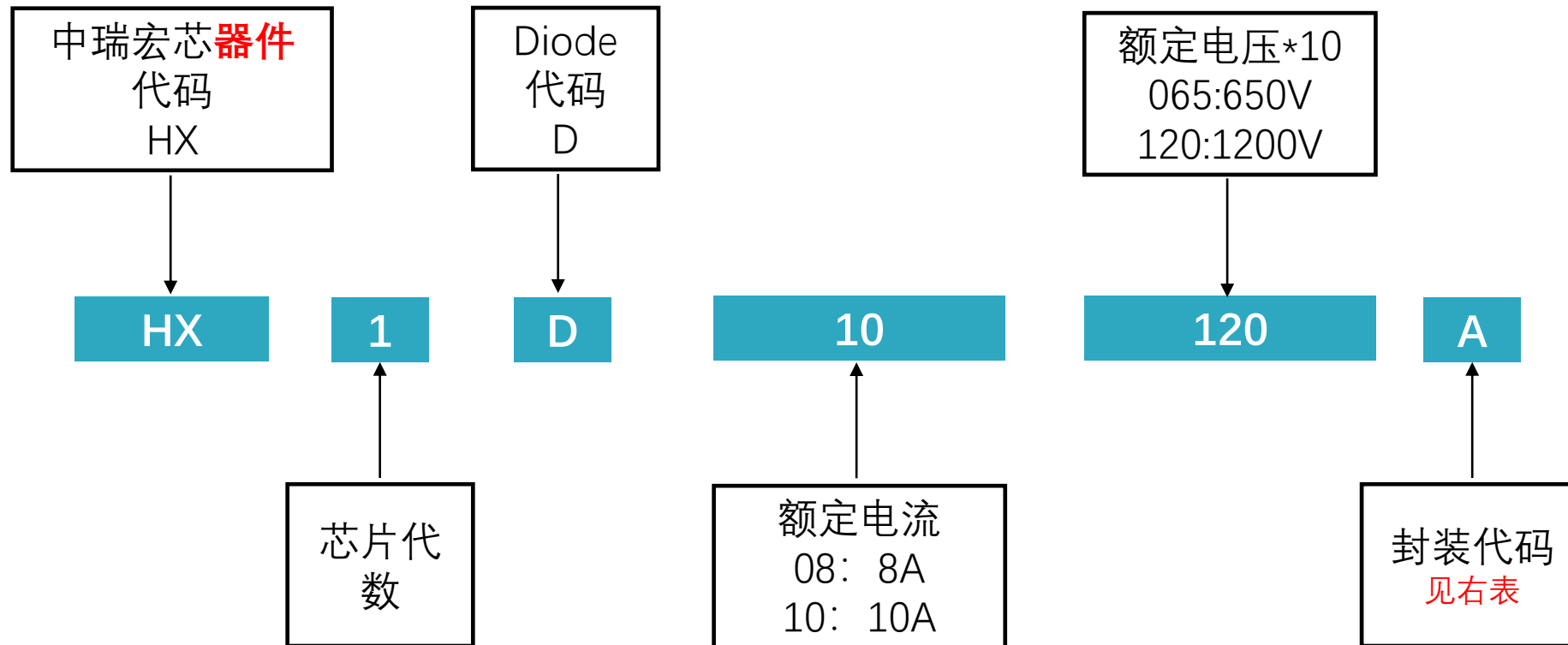

封装代码	封装型号
A	TO-220-2L
B	TO-220-3L
E	TO-252-2L
G	TO-263-2L
H	TO-247-2L
D	TO-247-3L
F	TO-220-Fullpack
I	TO-220 Isolated
Q	QFN8*8
N	QFN5*6
L	SOD123
M	SMAF
S	SMBF

MOS Device命名规则

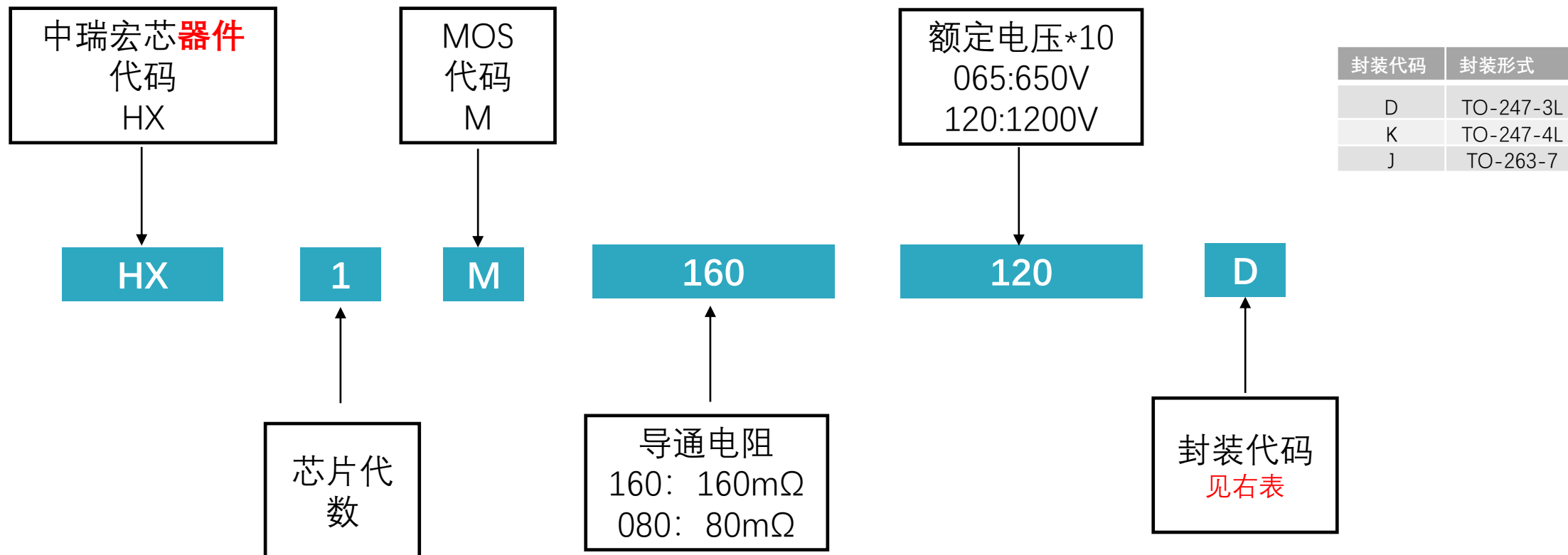

Diode Device命名规则

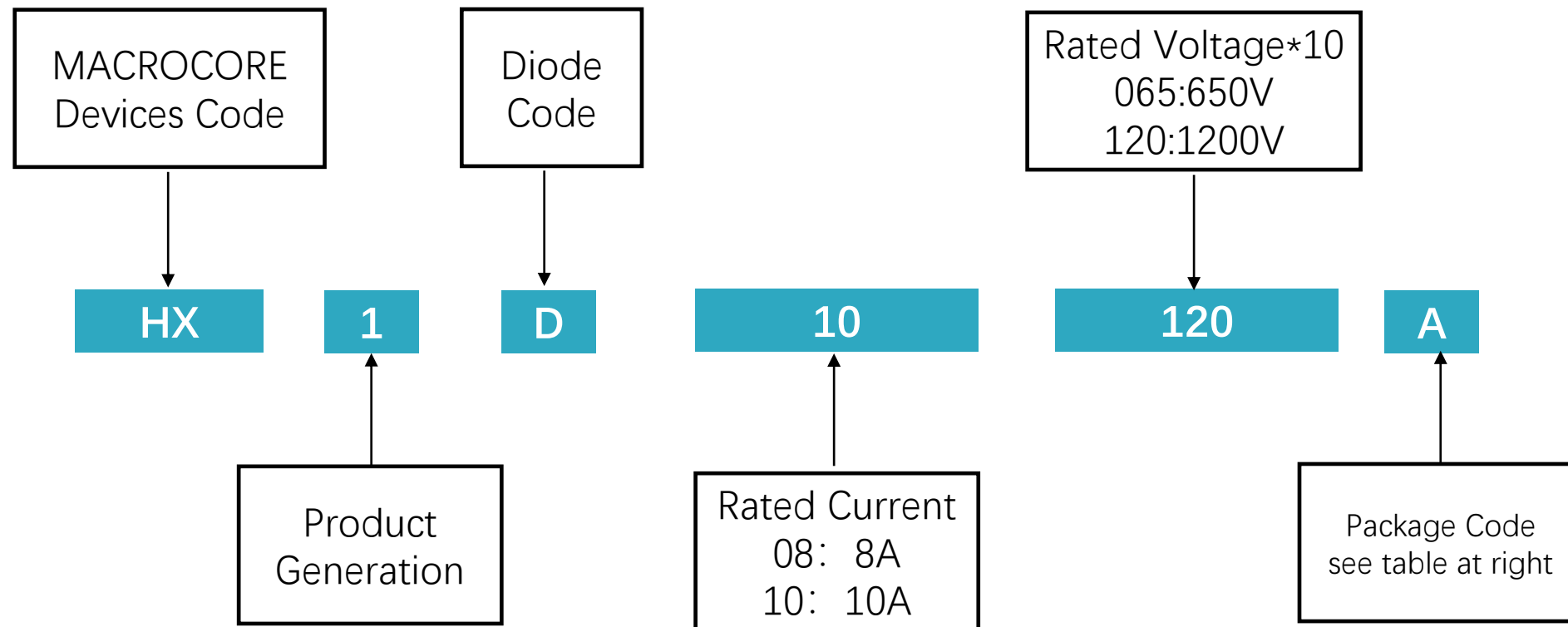

Package Type	Package Code
TO-220-2L	A
TO-220-3L	B
TO-252-2L	E
TO-263-2L	G
TO-247-2L	H
TO-247-3L	D
TO-220-Fullpack	F
TO-220 Isolated	I
QFN8*8	Q
QFN5*6	N
SOD123	L
SMAF	M
SMBF	S

MOS Device命名规则

